

# FINN-POWER



anto

# FINN-POWER EB

*Automated Bending Cell adds to the productivity of your sheet metal working process*

In many cases the press brake, the standard technical solution for the bending of sheet metal components, is not only the typical but also the most productive manufacturing method.

Yet, there are many manufacturing situations where an automated bending cell offers benefits far superior in terms of

- total manufacturing cost
- component quality
- automation level.

FINN-POWER's new EB bending cell is your optimal solution for bending

- large components
- from thin sheets
- in long series
- automatically

With FINN-POWER EB the machine operation cycle is fully automatic and includes the following stages: loading, rotation during the bending sequence, bending, and unloading.

## Operation

The machine is operated by a CNC and a PLC (Programmable Logic Controller). The CNC and the PLC exchange information and synchronism through digital I/O. The machine's main functions as well as all the axes involved in the bending are controlled by the CNC.

Bending generally starts from the outside edge of the sheet and continues towards the inside of the sheet, working one side after another in sequence. The sheet is loaded automatically onto the working table by a robot where a manipulator pushes it against the positioning pins. The manipulator holds the work piece firmly during all the manipulation phases.

The bending tool holds the required portion of sheet in position during the bending action. Two blades manipulate the portion protruding from between the counter-blade and the upper tool, upwards or downwards according to the nature of the bend (positive or negative) and the required angle, CNC programmable. The ready-bent component is automatically exited and the next flat work piece loaded.



# INGENIOUS BASIC PRINCIPLE – ROBUST, CAREFULLY ENGINEERED CONSTRUCTION

The bending principle of the FINN-POWER EB bending cell is simple and based on the following main components:

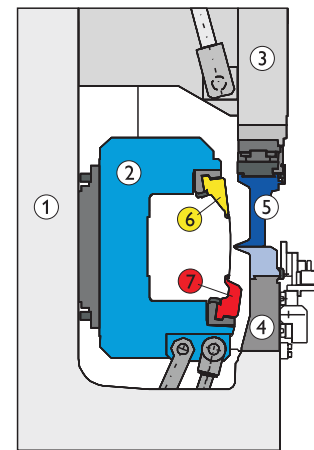

Two frames: the stationary main frame ① of the machine and a C-frame ② with hydraulically actuated swinging movement up-wards or downwards.

An upper tool ③ with hydraulically actuated vertical movement CNC controlled (parameter H1) and a fixed lower tool ④ for holding the work piece in position during bending.

Upper tool segments ⑤, which determine bend length.

Upper ⑥ and lower ⑦ blades, which transfer the bending force onto the sheet.

Key components in the material management of the cell are the very fast suction cup robot which loads the flat component, and the manipulator, which places it against numerically controlled positioning pins, rotates the work piece and, once all sides have been bent, transfers it onto the unloading conveyor. Thus the entire bending process can be automated, and the bending of components automatically continues as long as programmed.

## Axis interpolation

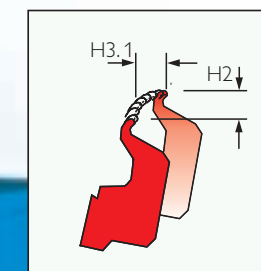
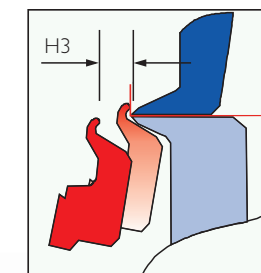
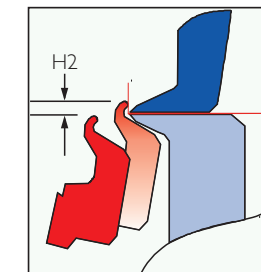
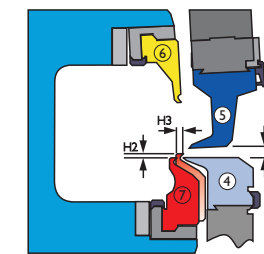

A fundamental characteristic of the EB bending technology is the movement of the blade. The contact line of the blade and the material being bent remains constant. This is achieved by numerically controlled interpolation of the two axes that operate blade movement.

This solution eliminates scratching of the material; thus even sensitive materials can be bent while high surface quality is retained.

H3 = Horizontal movement  
CNC processed

H2 = Vertical movement

$H3/1 = H3 + H2$ . The result is a curve movement due to the interpolation of two axes.



**There are many manufacturing situations where FINN-POWER EB provides superior cost efficiency in bending. Analyse your manufacturing tasks together with FINN-POWER – the latest technology offers the best in productivity.**

# A RANGE OF OPTIONAL EQUIPMENT AND FEATURES TO MEET YOUR SPECIFIC MANUFACTURING REQUIREMENTS

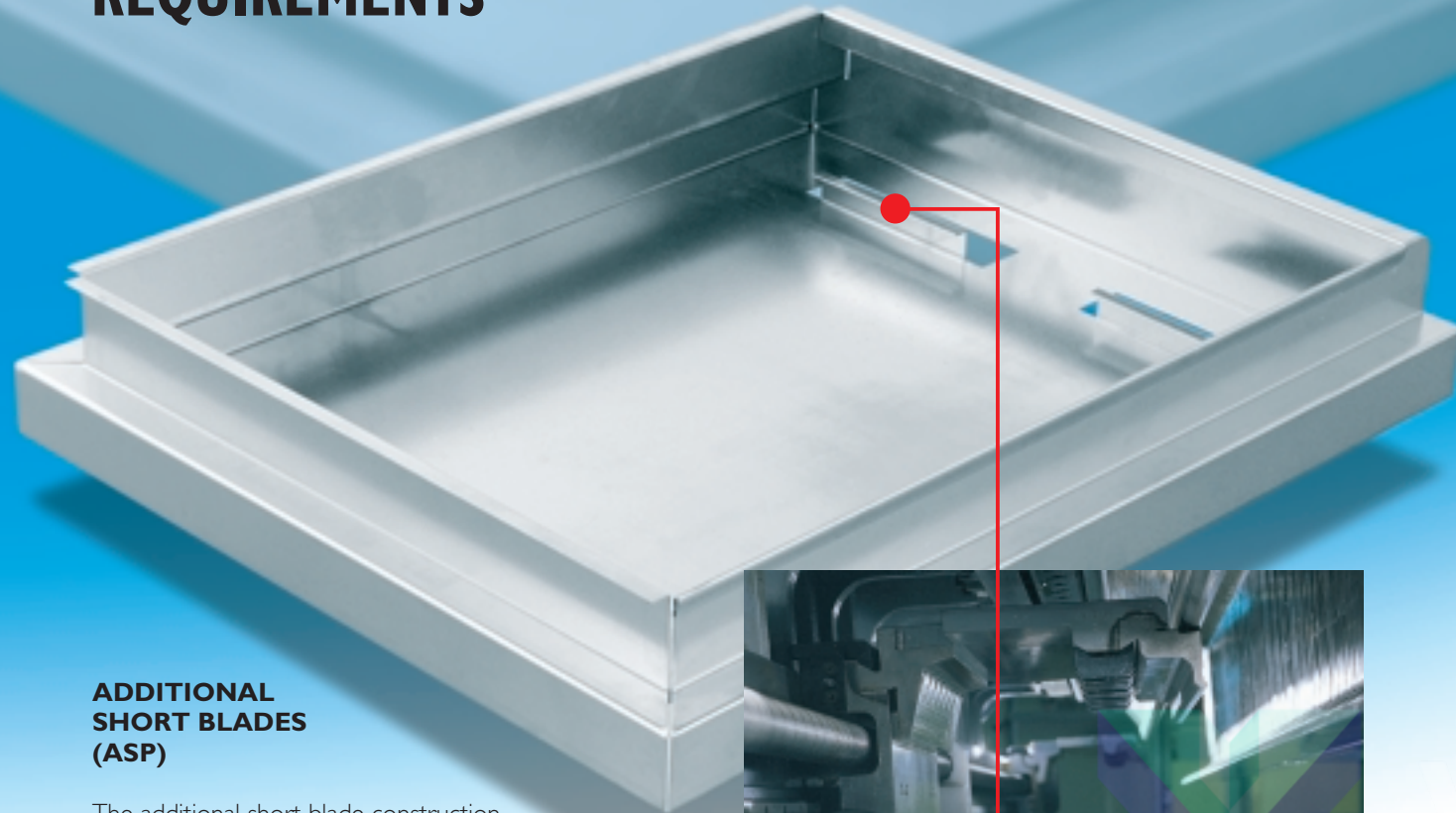

## ADDITIONAL SHORT BLADES (ASP)

The additional short blade construction consists of two numerically controlled carriages installed within the C frame structure. Short blades (standard length 500 mm, can reach up to 900 mm) are mounted onto the carriages and allow, for example, the bending of small wings. The option can be automatically activated and deactivated during the bending cycle. The bending can be performed either upward or downward, therefore positive and negative bending can be achieved even with the ASP.

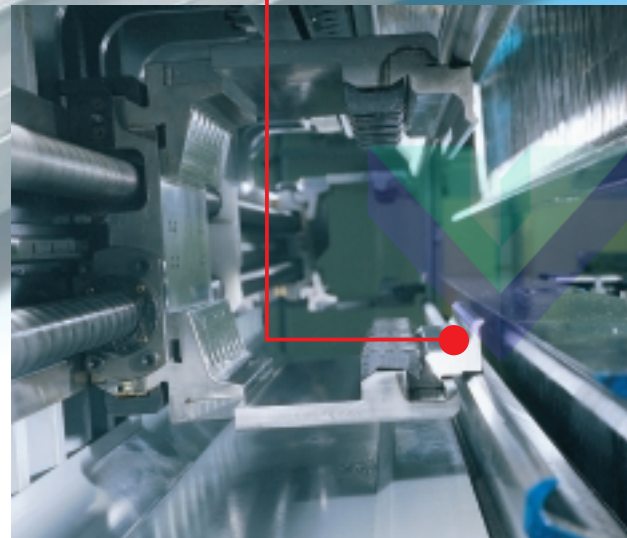

## INTEGRATED ENGRAVING UNIT (IEU)

The integrated engraving unit is a roll forming tool mounted on one of the carriages of the ASP. It is used for making a groove in the sheet to facilitate subsequent bending.



- ASP
- IEU
- HBD

## HYDRAULIC BENDING DIE (HBD)

Hydraulic dies can be mounted onto the ASP carriage for bending component the sides of which are not parallel or for bending portions of the sheet that would not be reached in other ways. The option is always a custom-made solution.

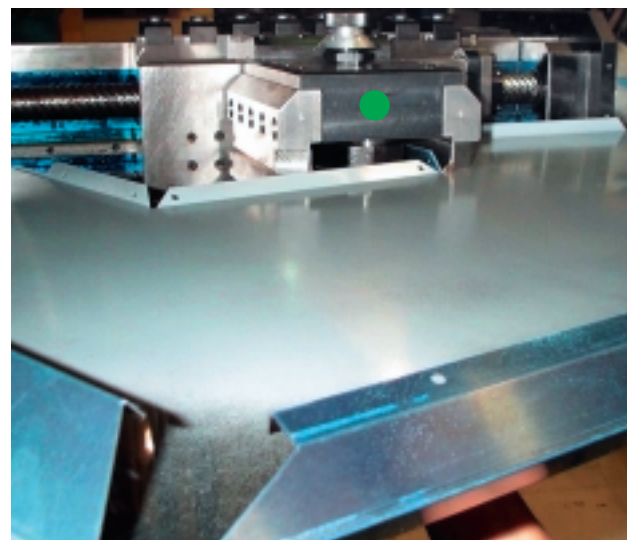

## AUTOMATIC TOOL CHANGE (ATC)

This option automates the changing of upper tool dimensions. The system consists of a central transfer device, two CNC controlled transfer units, side transfer units and a central tool segment storage. The side robots perform the coarse adjustment, when the dimension changes more than 6 mm, the fine adjustment is achieved by the central robot. The upper tool can therefore achieve any required length, by incremental steps of 6 mm.

## HYDRAULIC TOOL CLAMPING (HTC)

Changing upper tool dimensions is facilitated and made faster by the hydraulic tool clamping option. In order to change the upper tool dimension the operator simply needs to unlock the hydraulic clamp and press a clip to be able to move the segment into desired position.

## ADDITIONAL UPPER TOOL (AUT)

The AUT mechanism allows the changes of upper tool mechanism by lowering an additional tool segment below the standard upper tool segments. It is often required for making bends that are "hidden", i.e. when the bending point to reach is "shadowed" by the previously bent profile, and negative. Further, the possibility of using special tools provides additional versatility, like big radius bend, tube profiles, wide inward bending, holding of the sheet while pressing with the blades.

## CONTROL CABIN COOLER

Acceptable ambient temperature for the standard bending cell are: temperature +15° . . . +30° C. For operation in warmer temperatures a control cabinet cooler is required.

## REVERSED BENDING SEQUENCE (CLL)

In the standard bending cycle short sides are bent first and long ones afterwards. This sequence can be reversed with the CLL option, which forms two gaps in the upper tool, either symmetrical or asymmetrical to accommodate the bent edges of the longer sides.

# A RANGE OF OPTIONAL EQUIPMENT AND FEATURES TO MEET YOUR SPECIFIC MANUFACTURING REQUIREMENTS

## ADDITIONAL SHORT BLADES (ASP)

The additional short blade construction consists of two numerically controlled carriages installed within the C frame structure. Short blades (standard length 500 mm, can reach up to 900 mm) are mounted onto the carriages and allow, for example, the bending of small wings. The option can be automatically activated and deactivated during the bending cycle. The bending can be performed either upward or downward, therefore positive and negative bending can be achieved even with the ASP.

## INTEGRATED ENGRAVING UNIT (IEU)

The integrated engraving unit is a roll forming tool mounted on one of the carriages of the ASP. It is used for making a groove in the sheet to facilitate subsequent

## HYDRAULIC BENDING DIE (HBD)

Hydraulic dies can be mounted onto the ASP carriage for bending component the sides of which are not parallel or for bending portions of the sheet that would not be reached in other ways. The option is always a custom-made solution.

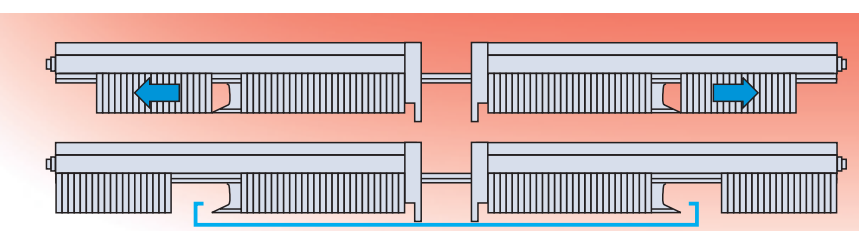
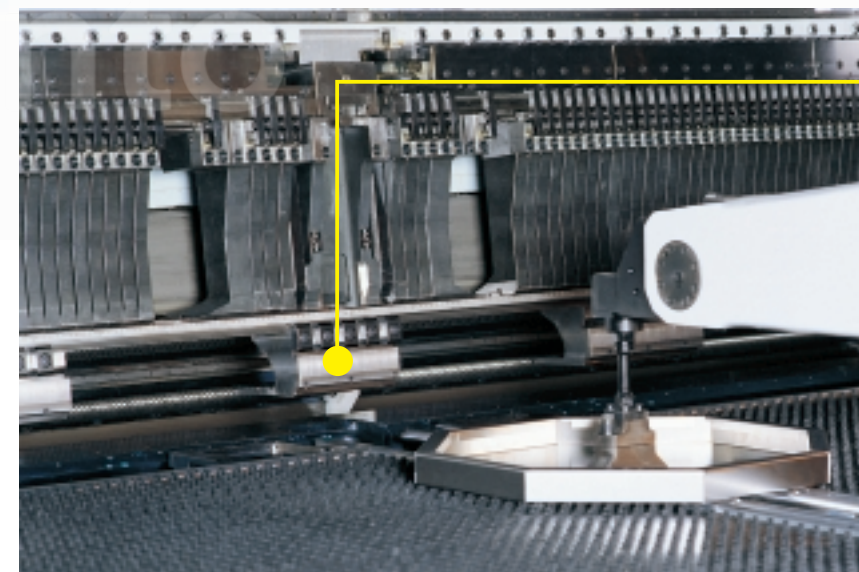
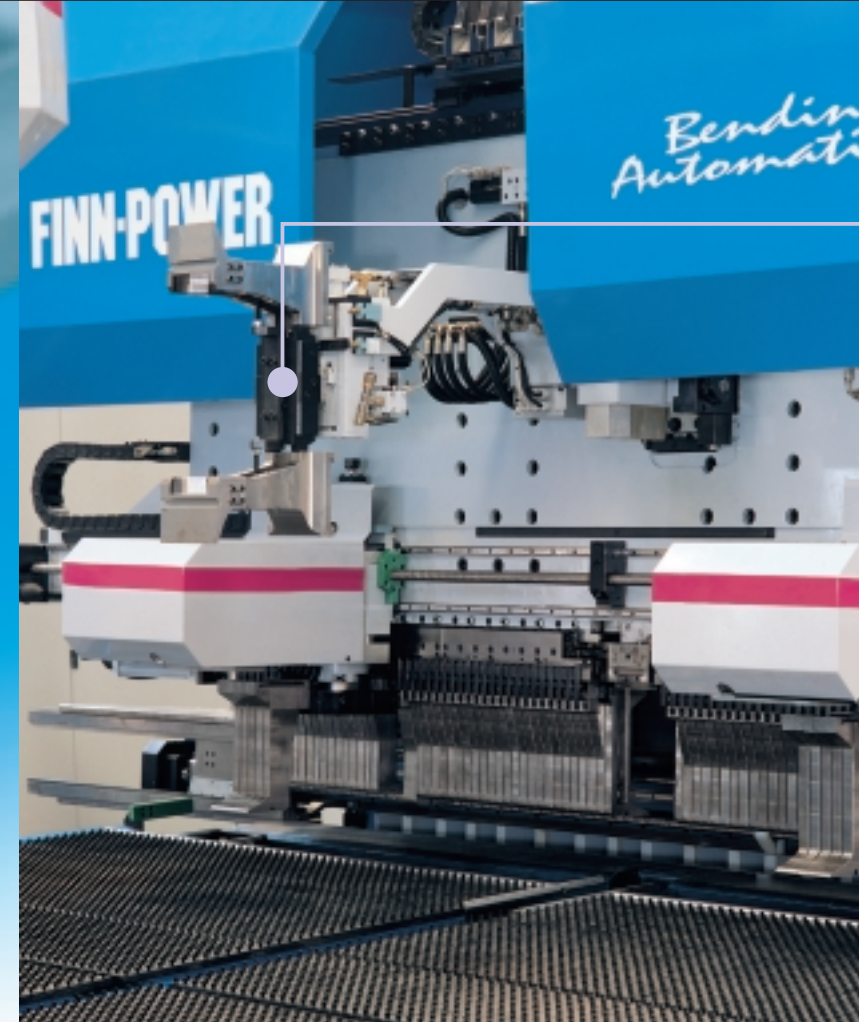

## REVERSED BENDING SEQUENCE (CLL)

In the standard bending cycle short sides are bent first and long ones afterwards. This sequence can be reversed with the CLL option, which forms two gaps in the upper tool, either symmetrical or asymmetrical to accommodate the bent edges of the longer sides.

## AUTOMATIC TOOL CHANGE (ATC)

This option automates the changing of upper tool dimensions. The system consists of a central transfer device, two CNC controlled transfer unit-side transfer units and a central tool segment storage. The side robots perform the coarse adjustment, when the dimension changes more than 6 mm, the fine adjustment is achieved by the central robot. The upper tool can therefore achieve any required length, by incremental steps of 6 mm.

## HYDRAULIC TOOL CLAMPING (HTC)

Changing upper tool dimensions is facilitated and made faster by the hydraulic tool clamping option. In order to change the upper tool dimension the operator simply needs to unlock the hydraulic clamp and press a clip to be able to move the segment into desired position.

## ADDITIONAL UPPER TOOL (AUT)

The AUT mechanism allows the changes of upper tool mechanism by lowering an additional tool segment below the standard upper tool segments. It is often required for making bends that are "hidden", i.e. when the bending point to reach is "shadowed" by the previously bent profile, and negative. Further, the possibility of using special tools provides additional versatility, like big radius bend, tube profiles, wide inward bending, holding of the sheet while pressing with the blades.

## CONTROL CABIN COOLER

Acceptable ambient temperature for the standard bending cell are: temperature +15° . . . +30° C. For operation in warmer temperatures a control cabinet cooler is required.

# MATERIAL MANAGEMENT OPTIONS

**Flexible, modular solutions for automated material management are a traditional FINN-POWER strength. The EB bending cell can be upgraded by using a range of options which prolong unmanned operation for added productivity and eliminate tedious work stages.**

## NEGATIVE LAST BEND (LBN)

If the last bend made is negative (i.e. downwards), the standard unloading conveyor placed in the middle of the machine cannot be used. With the LBN option, such components are unloaded by a carriage, that pushes them laterally out, without taking the part to the centre of the machine table.

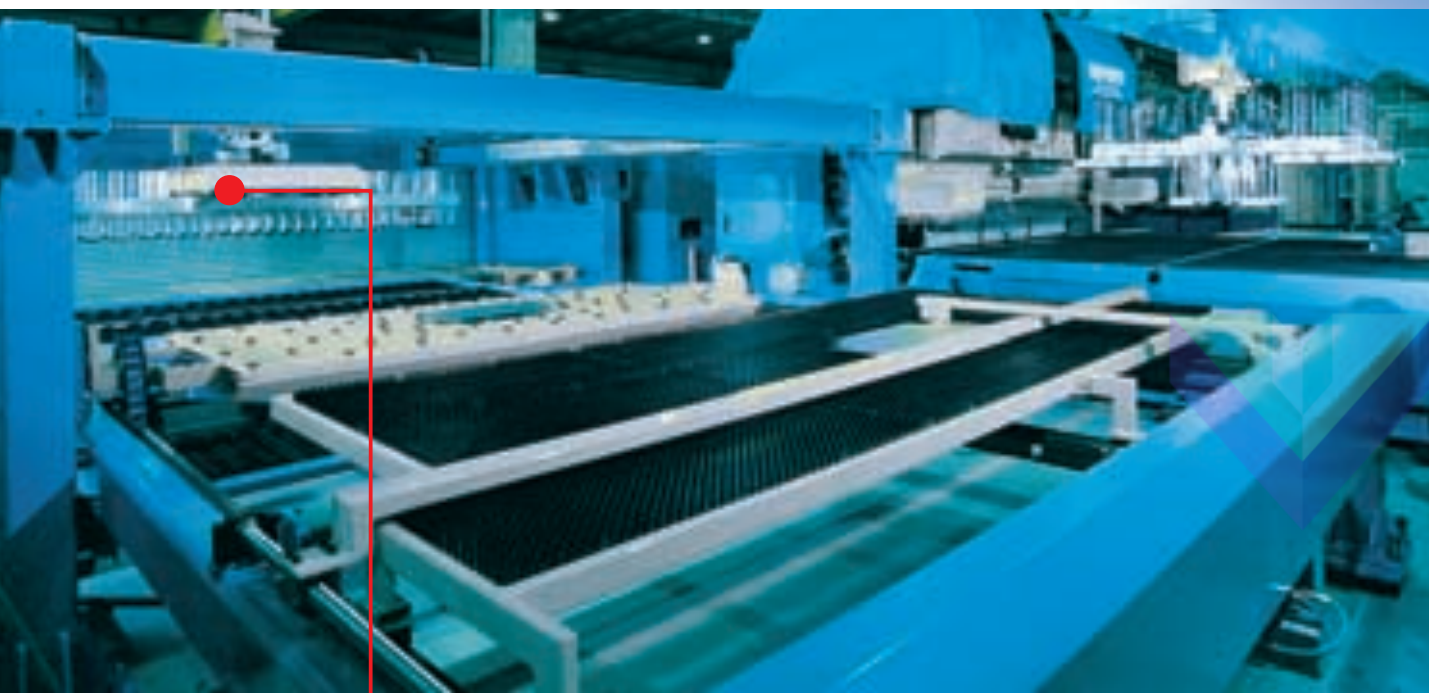
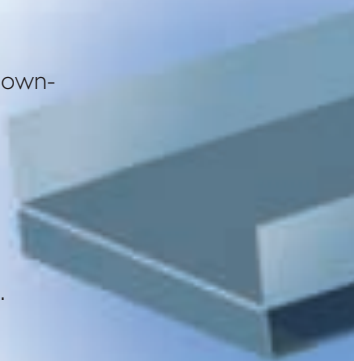

## SGR

FINN-POWER's SGR stacking robot provides the material management link between a Shear Genius punching – shearing cell and the EB bending cell. Its primary function is to load components either direct or with a buffering function as they are exited from the Shear Genius cell. It can also stack components on a separate pallet and load the bending cell from a pallet brought from outside the system.

## NONMAGNETIC MATERIAL SEPARATION (NMS)

With plastic coated sheets and under conditions where static electricity may be a problem, the NMS option eliminates it. The suction cup rows closest to the edges of the sheet operate at first to lift the edges for better sheet separation. Blowing compressed air between the sheets and additional steel brushes finally contribute to the separation. The option is for Stand-alone machines only.

## DOUBLE LOADING TABLE (DLT)

When the double loading table is used, a new stack of flat components can be loaded onto one table while the machine continues to operate using components from the other table. Available only for EB 3 machines.

## UNLOADING AND STACKING SYSTEM (USS)

The innovative idea of the USS option is to use the loading device for both loading the blank sheet and stacking the bent parts.

The USS loader picks up the components either from the standard loading table or from the NTR or SGR centring table and takes it to the machine for the bending. Meanwhile, the previously bent part is unloaded and centred on the TUT table. The loader picks up the part from the TUT table and stacks it as desired. The stacking area available is four euro pallets. There are several stacking addresses that can be combined to optimize area and product storage.

**FOR  
EXAMPL**

# FOR EXAMPLE...

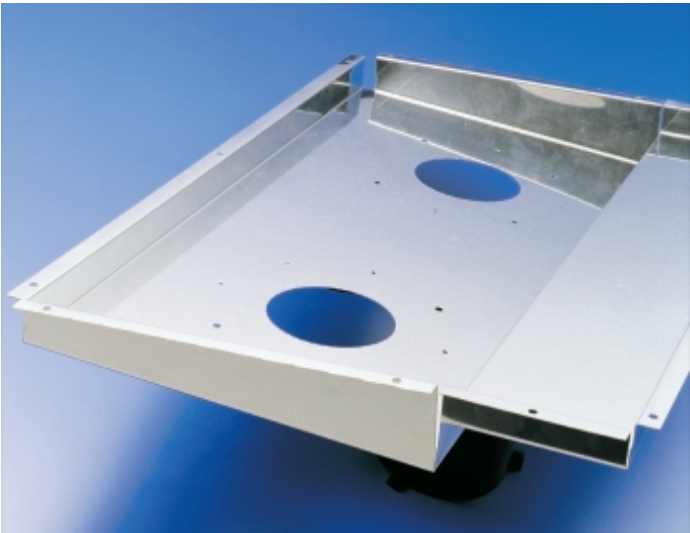
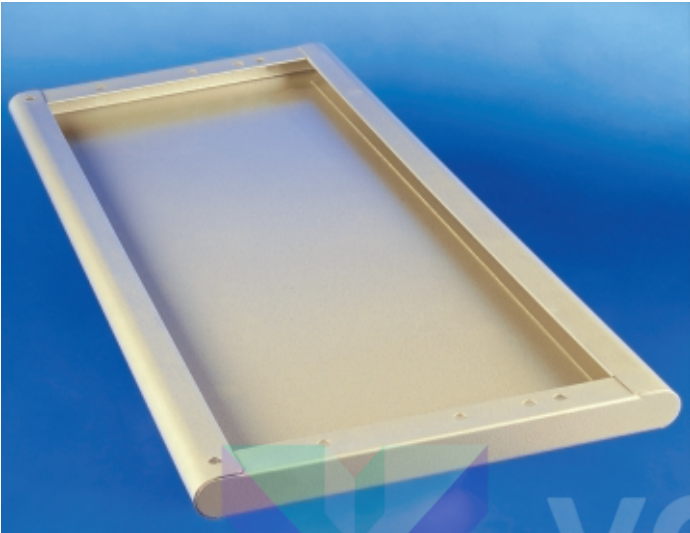
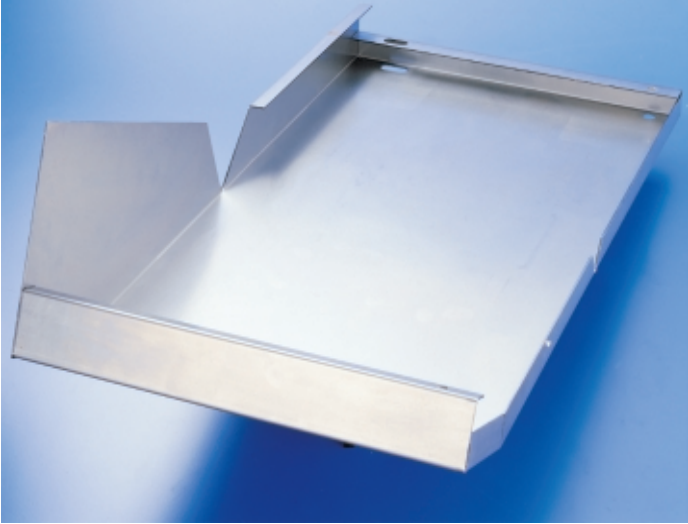



# PROFILES

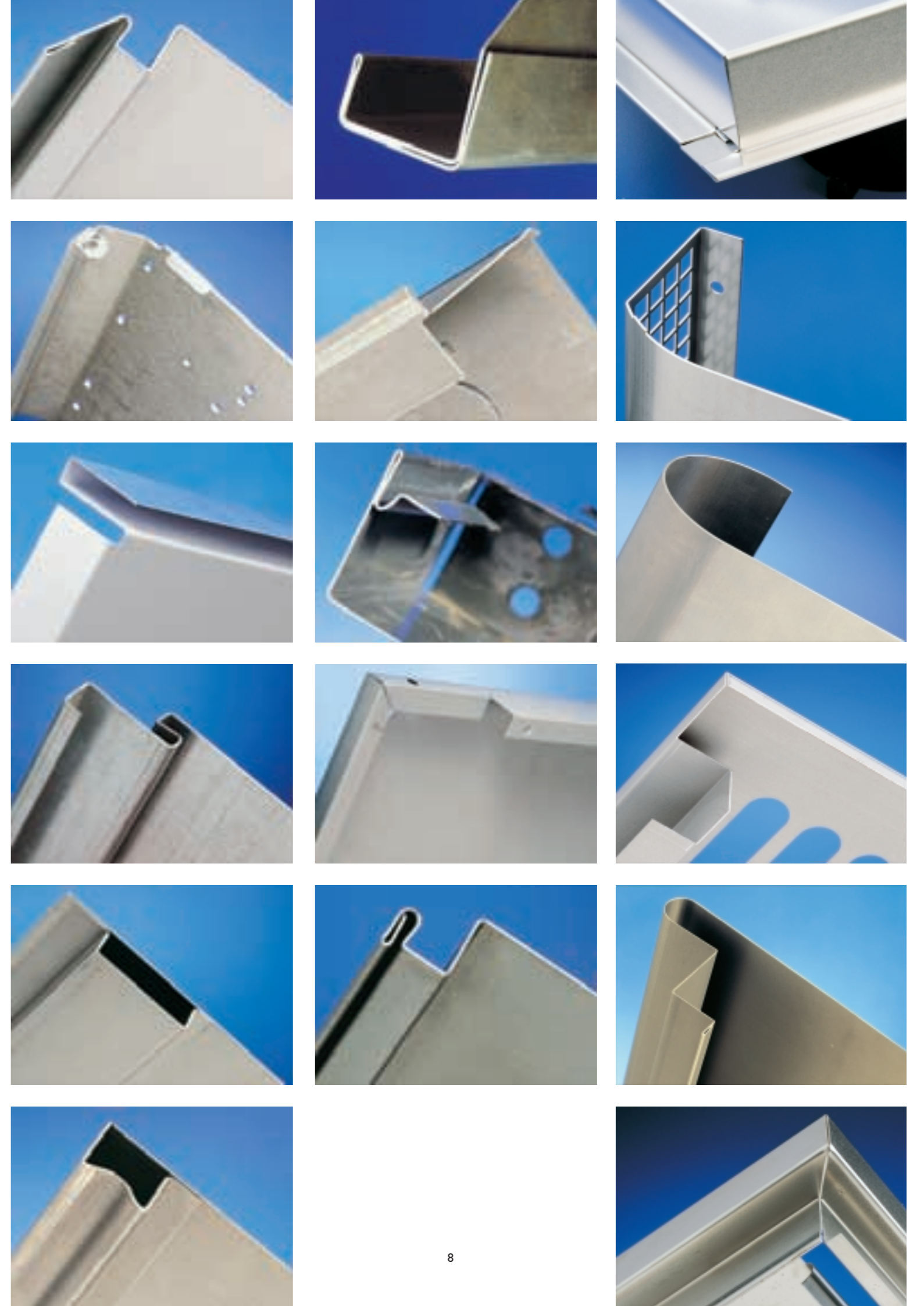



### ALT SET-UP

This option provides automatic adjustment of the loading unit and the positioning bars on the loading table. It shortens set-up times and facilitates the loading of a new stack.

### BUFFER STORAGES

FINN-POWER EB can be equipped with a buffer system for bent components to prolong periods of unmanned operation. The components are temporarily stored in vertical position on a buffer which is installed at right angles to the unloading conveyor.

### TILTING UNLOADING TABLE (TUT)

Instead of the standard table, a tilting unloading table can be used. This table is designed to allow the bent panels to be unloaded towards the operator side and grant a small buffering function (2-3 relatively small pieces). After the ready-bent component reaches the TUT table, a roll mechanism transfers the part to the end of the table, a location from which it is brought by conveyor belts to the operator side of the table.

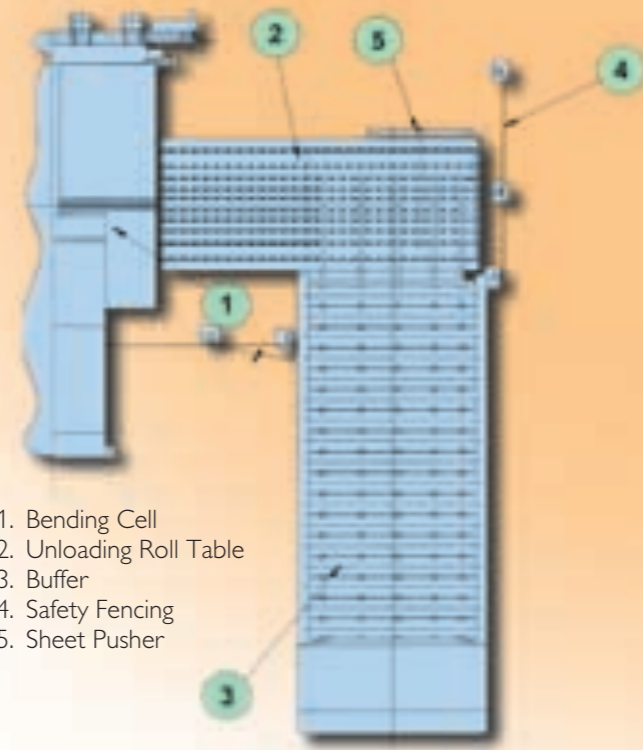

1. Bending Cell
2. Unloading Roll Table
3. Buffer
4. Safety Fencing
5. Sheet Pusher



FINN-POWER

# Technical information

Bending Cell EB	EB3	EB4	EB5	BC 32
Maximum bending length (mm)	1650	2150	2550	3250
Minimum length between the bends (mm)	350	350	350	350
Maximum width between the bends (mm)	140	160	160	180
Sheet length, min . . . max (mm)	370 . . . 1800	370 . . . 2450	370 . . . 2850	370 . . . 3500
Sheet width, min . . . max (mm)	160 . . . 1200	180 . . . 1500	180 . . . 1500	200 . . . 1650
Maximum panel diagonal (mm)	1900	2700	3000	3600
Maximum bend height SH type (mm)	200 (127 mm type N)	200 (127 mm type N)	200 (127 mm type N)	200 (127 mm type N)
Maximum re-entering bend (mm)	55	55	55	55
Maximum stack height (mm) *	220	220	220	220
Maximum pack weight (kg) *	3000	3000	3000	3000
Sheet planarity (mm)	10	10	10	10
Maximum material thickness (mm)				
Fe 37 steel	2.0	2.5	3.2	2.5
Stainless steel	1.5	1.8	2.2	1.8
Aluminium	3.0	3.5	4.0	3.0
Minimum material thickness (mm)	0.5	0.5	0.5	0.6
Minimum external radius	1.5 . . . 2 x sheet thickness	1.5 . . . 2 x sheet thickness	1.5 . . . 2 x sheet thickness	1.5 . . . 2 x sheet thickness
Bend angle (degrees)	-135 . . . +135	-135 . . . +135	-135 . . . +135	-135 . . . +135
Max. number of bends per side	20	20	20	20
Angle tolerance	± 0°40'	± 0°40'	± 0°40'	± 0°40'
Bend dimension tolerance (mm)	± 0.2	± 0.2	± 0.2	± 0.2
Straightness and parallelism (mm)	0.4	0.4	0.6	0.6
Power: max installed (kW)	58	66	66	66
Average absorbed (kW)	22	30	30	30
Voltage (V)	400 (50 / 60 Hz)	400 (50 / 60 Hz)	400 (50 / 60 Hz)	400 (50 / 60 Hz)
Main switch (A)	160	160	160	160
Compressed air consumption (½", NI/min)	12	12	12	12
Compressed air pressure (bar)	6	6	6	6

\* Stand alone machines only



Lillbacka Corporation  
P.O. Box 38  
FIN-62201 Kauhava  
Finland  
Tel. + 358 6 428 2111  
Fax + 358 6 428 2244  
www.finn-power.com

FINN-POWER International, Inc.  
710 Remington Road  
Schaumburg, Illinois 60173  
USA  
Tel. + 1 847 885 3200  
Fax + 1 847 885 9692  
www.finnpower.com

FINN-POWER Lillbacka GmbH  
Postfach 54  
D-85399 Hallbergmoos  
Germany  
Tel. + 49 811 55330  
Fax + 49 811 1667  
www.finn-power.de

FINN-POWER Lillbacka SARL  
Techniparc - 5, rue Boole  
F-91240 Saint Michel Sur Orge  
France  
Tél. + 33 1 69 46 55 80  
Fax + 33 1 69 46 55 81  
www.finn-power.fr

FINN-POWER Italia S.r.l.  
Via Papa Giovanni XXIII, 79  
IT-25015 Desenzano del Garda (BS)  
Italy  
Tel. + 39 030 911 8111  
Fax + 39 030 911 8119

FINN-POWER Bending Cells, ITEM1082.  
Subject to changes without prior notice.  
Copyright Lillbacka Corporation May 2000